

U.S. TYPE ANCHOR SHACKLES

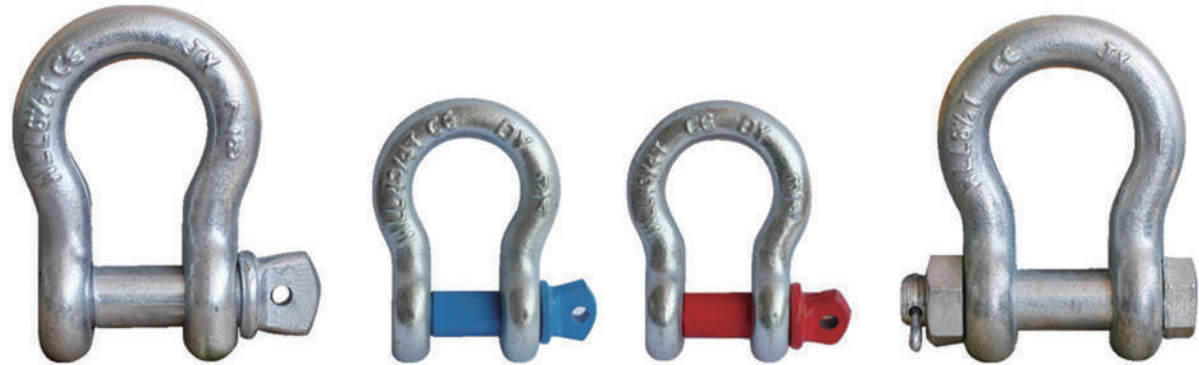

G-209

G-2130

Screw pin anchor shackle meet the requirements of Federal Specification RR-C-271D Type IVA, Grade A, Class 2

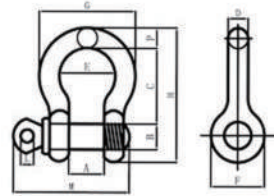

Safety anchor shackle with hexagon bolt-nut and cotter pin meet the requirements of Federal Specification RR-C-271D Type IVA, Grade A, Class 3

Nominal Size (in.)	WLL (t)	Weight Each (kg)	Dimensions(mm)											Tolerance +/-	
			A	B	C	D	E	F	G	H	L	M	P	C	A
3/16	0.3	0.03	9.65	6.35	22.4	4.85	15.2	14.2	24.9	37.3	4.06	28.4	4.85	1.50	1.50
1/4	0.5	0.05	11.9	7.85	28.7	6.35	19.8	15.5	32.5	46.7	4.85	35.1	6.35	1.50	1.50
5/16	0.75	0.09	13.5	9.65	31.0	7.85	21.3	19.1	37.3	53.0	5.60	42.2	7.85	3.30	1.50
3/8	1	0.14	16.8	11.2	36.6	9.65	26.2	23.1	45.2	63.0	6.35	51.5	9.65	3.30	1.50
7/16	1.5	0.17	19.1	12.7	42.9	11.2	29.5	26.9	51.5	74.0	7.85	60.5	11.2	3.30	1.50
1/2	2	0.33	20.6	16.0	47.8	12.7	33.3	30.2	58.5	83.5	9.65	68.5	12.7	3.30	1.50
5/8	3.25	0.62	26.9	19.1	60.5	16.0	42.9	38.1	74.5	106	11.2	85.0	17.5	6.35	1.50
3/4	4.75	1.07	31.8	22.4	71.5	19.1	51.0	46.0	89.0	126	12.7	101	20.6	6.35	1.50
7/8	6.5	1.64	36.6	25.4	84.0	22.4	58.0	53.0	102	148	12.7	114	24.6	6.35	1.50
1	8.5	2.28	42.9	28.7	95.5	25.4	68.5	60.5	119	167	14.2	129	26.9	6.35	1.50
1-1/8	9.5	3.36	46.0	31.8	108	29.5	74.0	68.5	131	190	16.0	142	31.8	6.35	1.50
1-1/4	12	4.31	51.5	35.1	119	32.8	82.5	76.0	146	210	17.5	156	35.1	6.35	1.50
1-3/8	13.5	6.14	57.0	38.1	133	36.1	92.0	84.0	162	233	19.1	174	38.1	6.35	3.30
1-1/2	17	7.80	60.5	41.4	146	39.1	98.5	92.0	175	254	20.6	187	41.1	6.35	3.30
1-3/4	25	12.6	73.0	51.0	178	46.7	127	106	225	313	25.4	231	57.0	6.35	3.30
2	35	20.4	82.5	57.0	197	53.0	146	122	253	348	31.0	263	60.0	6.35	3.30
2-1/2	55	38.9	105	70.0	267	69.0	184	145	327	453	35.1	330	79.5	6.35	6.35
3	85	66	127	83	330	76	200	165	365	540	41	419	97	6.35	6.35
3-1/2	120	108	133	96	372	92	229	203	419	600	46	482	105	6.35	6.35
4	150	150	140	108	368	104	254	229	468	620	50	502	116	6.35	6.35

U.S. TYPE CHAIN SHACKLES



G-210

G-2150

Screw pin chain shackle meet the requirements of Federal Specification RR-C-271D Type IVB, Grade A, Class 2

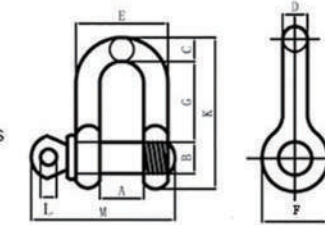

Safety chain shackle with hexagon bolt-nut and cotter pin meet the requirements of Federal Specification RR-C-271D Type IVB, Grade A, Class 3

Nominal Size (in)	WLL (t)	Weight Each (kg)	Dimensions(mm)											Tolerance +/-	
			A	B	C	D	E	F	G	K	L	M	G	A	
1/4	0.5	0.05	11.9	7.85	6.35	6.35	24.6	15.5	22.4	40.4	4.85	35.1	1.50	1.50	
5/16	0.75	0.08	13.5	9.65	7.85	7.85	29.5	19.1	26.2	48.5	5.60	42.2	1.50	1.50	
3/8	1	0.13	16.8	11.2	9.65	9.65	35.8	23.1	31.8	58.5	6.35	51.5	3.30	1.50	
7/16	1.5	0.20	19.1	12.7	11.2	11.2	41.4	26.9	36.6	67.5	7.85	60.5	3.30	1.50	
1/2	2	0.27	20.6	16.0	12.7	12.7	46.0	30.2	41.4	77.0	9.65	68.5	3.30	1.50	
5/8	3.25	0.57	26.9	19.1	15.7	16.0	58.5	38.1	51.0	95.5	11.2	85.0	3.30	1.50	
3/4	4.75	1.20	31.8	22.4	20.6	19.1	70.0	46.0	60.5	115	12.7	101	6.35	1.50	
7/8	6.5	1.43	36.6	25.4	24.6	22.4	81.0	53.0	71.5	135	12.7	114	6.35	1.50	
1	8.5	2.15	42.9	28.7	25.4	25.4	93.5	60.5	81.0	151	14.2	129	6.35	1.50	
1-1/8	9.5	3.06	46.0	31.8	31.8	28.7	103	68.5	91.0	172	16.0	142	6.35	1.50	
1-1/4	12	4.11	51.5	35.1	35.1	31.8	115	76.0	100	191	17.5	156	6.35	3.30	
1-3/8	13.5	5.28	57.0	38.1	38.1	35.1	127	84.0	111	210	19.1	174	6.35	3.30	
1-1/2	17	7.23	60.5	41.4	41.1	38.1	137	92.0	122	230	20.6	187	6.35	3.30	
1-3/4	25	12.1	73.0	51.0	54.0	44.5	162	106	146	279	25.4	231	6.35	3.30	
2	35	19.2	82.5	57.0	60.0	51.0	184	122	172	312	31.0	263	6.35	3.30	
2-1/2	55	32.5	105	70.0	66.5	66.5	238	145	203	377	35.1	330	6.35	6.35	
3	85	66	127	83	330	76	200	165	365	540	41	419	6.35	6.35	
3-1/2	120	108	133	96	372	92	229	203	419	600	46	482	6.35	6.35	
4	150	150	140	108	368	104	254	229	468	620	50	502	6.35	6.35	

COMMERCIAL TYPE TURNBUCKLES

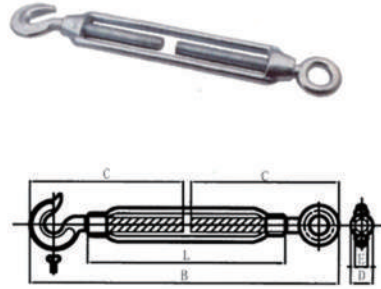

Size (mm)	WLL (kg)	Dimensions(mm)						Weight (lbs)
		B	C	D	E	F	L	
6x100	100	145	215	12	10	6	100	0.35
8x125	200	185	280	14	12	8	125	0.53
10x150	300	210	325	16	14	9	150	0.79
12x200	500	275	430	19	18	11	200	1.41
16x250	1000	345	540	23	24	14	250	3.18
20x300	1500	435	670	28	26	18	300	4.96
22x330	2200	480	740	34	32	20	330	7.79
24x350	3000	555	830	36	36	21	350	9.58

DIN 1480 TURNBUCKLES DIN 1480

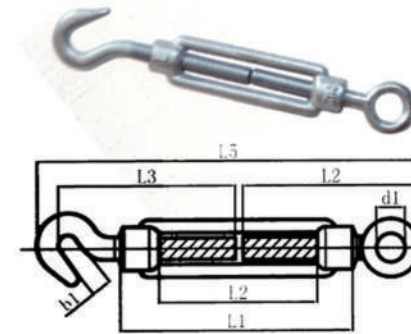

Size (mm)	Dimensions(mm)							Weight 100pcs(lbs)
	L1	L2	L3	bl	L4	dl	L5	
M6	110	80	85	8.5	80	9	172	21.0
M8	110	75	85	11	84	10	182	36.4
M10	125	85	112	13.5	105	14	213	64.0
M12	125	80	117	15.5	115	16	238	94.9
M14	140	90	122	18.5	122	18	263	136.8
M16	170	110	138	19	165	22	320	203.0
M20	200	130	170	20.5	167	24	367	359.7
M22	220	145	185	26	167	27	398	485.4
M24	255	170	205	26	205	27	447	662.0
M30	255	160	225	33	255	31	512	1015.0
M36	295	180	255	44	276	43	568	1694.6
M42	330	200	340	48	260	49	683	2846.4
M48	355	195	360	58	300	58	755	4633.7

JIS TYPE FRAME TURNBUCKLES

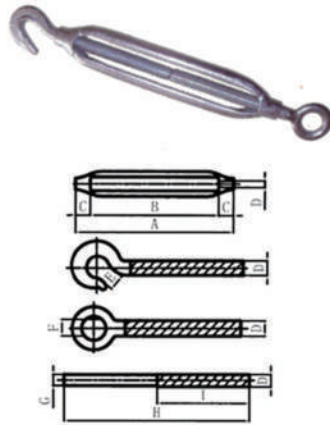

Size(D)	Body Only				Eye&Eye			Hook&Eye		Hook & Hook			With Stubs					
	A	B	C	T.L	W/PC	F	T.L	W/PC	T.L	W/PC	E	T.L	W/PC	H	I	G	W/PC	
6	100	4	78	11	1	2.21	10	0.1	0.3	0.04	0.25	9	0.04	0.25	80	50	5.3	11.69
8	125	5	100	12.5	1.2	2.65	12	0.2	0.5	0.08	0.48	9	0.08	0.47	100	63	6.9	15.23
9	150	6	120	12.5	1.5	3.31	16	0.5	0.7	0.15	0.65	11	0.15	0.64	130	75	8.3	18.31
12	200	8	164	18	2	4.41	20	2	1.3	0.35	1.29	16	0.35	1.26	150	100	11.2	24.71
16	250	10	202	21.5	3	6.62	22	3	2.4	0.7	2.32	19	0.7	2.27	180	125	14.2	31.33
19	300	12	250	25	4	8.83	28	4	3.9	1	3.93	20	1	3.91	220	150	17.2	37.95
22	325	13	269	28	5	11.03	33	5	5.6	1.5	5.69	21	1.5	5.74	250	165	20.3	44.79
25	350	14	285	32.5	6	13.24	35	6	8.4	2	8.32	26	2	8.21	270	175	23.3	51.41
32	400	16	310	45	8	17.65	36*70	10	16.8	3	16.6	34	3	16.4	300	200	29	63.99
38	450	18	350	55	10	22.07	40*80	15	29.8	4	28.2	35	4	28.5	330	225	38	83.85

DIN 1478 TURNBUCKLES DIN1478

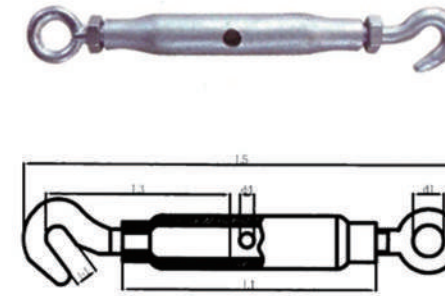

Size (mm)	Dimensions (mm)										Total Length Screwed in L5	Weight 100pcs (lbs)
	Body Length L1(mm)	Adjustable (mm)	d4	Hook L3 bl		Eye L3 dl						
M6	110	90	6	85	8.5	80	9				172	25.6
M8	110	85	8	85	11	84	10				182	41.92
M10	125	95	8	112	13.5	105	14				213	68.4
M12	125	90	10	117	15.5	115	16				238	92.67
M16	170	120	10	138	19	165	22				320	196.38
M20	200	140	12	170	20.5	167	24				367	348.63
M24	255	180	12	205	26	205	27				447	644.3
M30	255	160	16	225	33	255	31				512	948.8
M36	295	180	16	255	44	276	43				568	1334.95
M42	330	200	20	340	48	260	49				683	2559.57
M48	355	210	20	360	58	300	58				755	3530.45

KOREAN TYPE TURNBUCKLE

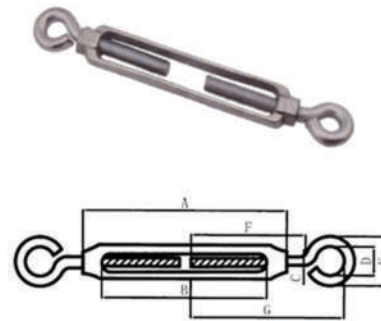

Size(in)	Dimensions(mm)							Weight(lbs)
	A	B	C	D	E	F	G	
3/16"	57.4	41.2	41.5	18.4	15	36	54.6	66
5/16"	90	70	8	11	22	65	95	320
3/8"	160	130	9	17	30	85	130	761
1/2"	190	155	10	20	30	95	150	1236
1/2"(Long)	255	215	10	30	35	140	190	1743
5/8"	250	200	15	25	45	130	190	2471
5/8"(Long)	350	300	15	30	45	180	240	3398
3/4"	250	200	20	35	45	140	210	3685
3/4" (Long)	300	245	20	40	55	170	240	4523

RIGGING SCREW

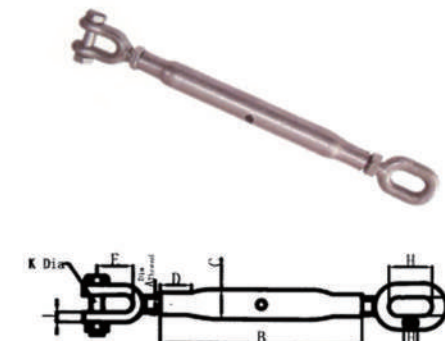

WLL (m. t)	Dia Screw A	Length of Body B	Dia of Body C	Dimensions(mm)									Weight (lbs)
				D JAW				E OVALEYE					
				Length				Inside					
				Dia D1	Dia D2	Length D3	Hidht D4	Dia E1	Length E2	Hidht E3			
0.1	6	102	12	3	5	15	7	6	15	8	0.24		
0.15	8	110	15	4	6	16	9	7	19	10	0.5		
0.375	10	152	21	5	8	21	11	8	25	11	0.62		
0.5	12	175	27	6	10	25	13	11	30	14	1.76		
0.75	16	229	27	10	12	40	18	14	41	16	3.09		
1.125	20	229	33	12	16	45	20	16	51	22	4.41		
1.6	22	305	33	15	18	48	24	16	51	22	7.72		
2	24	325	42	16	22	65	28	19	57	25	8.81		
2.75	28	356	48	18	22	59	30	19	57	28	9.92		
3.75	33	381	48	20	27	62	34	22	65	35	14.3		
4.25	35	381	60	22	28	68	38	22	65	36	17.64		
5	39	406	60	24	33	74	42	25	74	38	24.25		

US TYPE DROP FORGED WIRE ROPE CLIPS



Size (in)	Dimensions(in)								Weight 100pcs(lbs)
	A	B	C	D	E	F	G	H	
1/8	0.22	0.72	0.44	0.47	0.37	0.38	0.81	0.99	6
3/16	0.25	0.97	0.56	0.59	0.50	0.44	0.94	1.18	10
1/4	0.31	1.03	0.5	0.75	0.66	0.56	1.19	1.43	19
5/16	0.38	1.38	0.75	0.88	0.73	0.69	1.31	1.66	28
3/8	0.44	1.5	0.75	1	0.91	0.75	1.63	1.94	48
7/16	0.5	1.88	1	1.19	1.13	0.88	1.91	2.28	78
1/2	0.5	1.88	1	1.19	1.13	0.88	1.91	2.28	80
9/16	0.56	2.25	1.25	1.31	1.34	0.94	2.06	2.5	109
5/8	0.56	2.25	1.25	1.31	1.34	0.94	2.06	2.5	110
3/4	0.62	2.75	1.44	1.5	1.39	1.06	2.25	2.84	142
7/8	0.75	3.12	1.62	1.75	1.58	1.25	2.44	2.16	212
1	0.75	3.5	1.81	1.88	1.77	1.25	2.63	3.47	252
11/8	0.75	3.88	2	2	1.91	1.25	2.81	3.59	283
11/4	0.88	4.44	2.22	2.34	2.17	1.44	3.13	4.13	438
13/8	0.88	4.44	2.22	2.34	2.31	1.44	3.13	4.19	442
11/2	0.88	4.94	2.38	2.59	2.44	1.44	3.41	4.44	544
15/8	1	5.31	2.62	2.75	2.66	1.63	3.63	4.75	704
13/4	1.13	5.75	2.75	3.06	2.92	1.81	3.81	5.24	934
2	1.25	6.44	3	3.38	3.03	2	4.44	5.88	1300
21/4	1.25	7.13	3.19	3.88	3.19	2	4.56	6.38	1600
21/2	1.25	7.69	3.44	4.13	3.69	2	4.69	6.63	1900
23/4	1.25	8.31	3.56	4.38	4.88	2	5	6.88	2300
3	1.5	9.19	3.88	4.75	4.44	2.38	5.31	7.61	3100
31/2	1.5	10.75	4.5	5.5	6	2.38	6.19	8.38	4000

US TYPE GALV MALLEABLE WIRE ROPE CLIPS

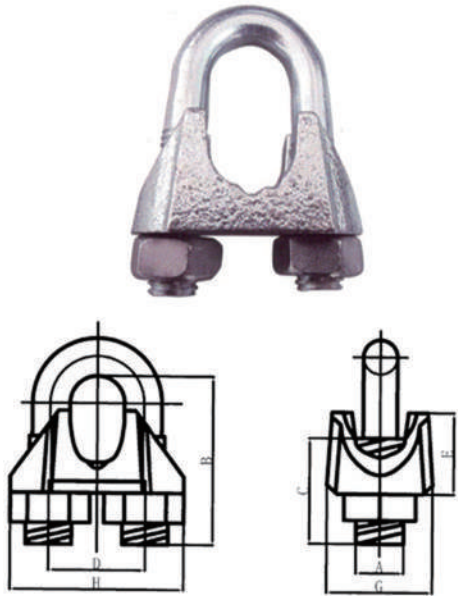

Size (in)	Dimensions(in)								Weight 100pcs (lbs)
	A	B	C	D	E	G	H		
1/8	1/4	13/16	1/2	1/2	7/16	1/2	15/16	3.3	
3/16	1/4	31/32	5/8	9/16	1/2	9/16	11/16	6.6	
1/4	5/16	17/32	7/8	11/16	5/8	11/16	13/8	11.42	
5/16	5/16	17/32	7/8	11/16	11/16	11/16	13/8	13.1	
3/8	3/8	15/8	1	7/8	13/16	7/8	15/8	22	
7/16	3/8	15/8	1	7/8	13/16	15/16	15/8	25.2	
1/2	7/16	2	11/4	1	11/16	1	17/8	38.4	
9/16	1/2	25/16	115/32	13/16	13/16	11/8	23/16	49.73	
5/8	1/2	25/16	115/32	13/16	15/16	11/8	23/16	54.76	
3/4	9/16	29/16	13/4	111/32	11/2	11/4	27/16	80.53	
7/8	5/8	31/16	113/16	15/8	13/4	13/4	27/8	117.35	
1	5/8	33/8	21/16	13/4	115/16	2	3	150.6	
11/8	3/4	37/8	23/16	21/16	23/16	21/8	37/16	243	
11/4	3/4	37/8	23/16	21/16	23/8	21/2	37/16	262	
13/8	7/8	41/2	2	29/16	27/8	31/8	43/16	456	
11/2	7/8	41/2	2	29/16	3	31/4	41/4	512	

**DIN741 Malleable Wire Rope Clips
DIN741**

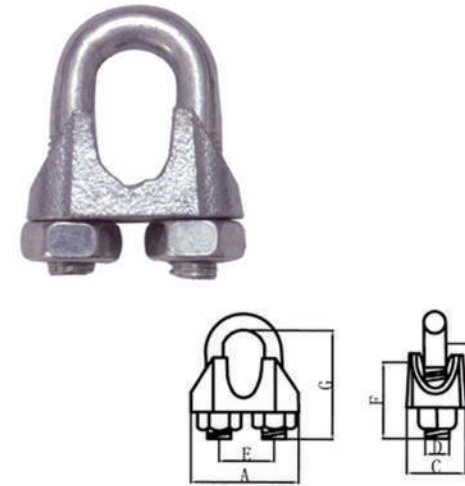

Size (mm)	Dimensions(mm)							Weight 100pcs(lbs)
	A	B	C	D	E	F	G	
3	21	10	10	4	9	12	16.6	3.09
5	23	10	11	5	11	13	19.65	3.3
6.5	26	11	12	5	13	15	23.65	4.63
8	30	15	14	6	16	19	28.85	9.04
10	34	17	18	8	19	22	35	15
11	36	18	19	8	20	22	37	15.87
13	40	21	23	10	24	30	46.24	28.7
14	44	22	23	10	25	30	48.24	29.76
16	50	26	26	12	29	33	52.5	46.3
19	54	30	29	12	32	38	64.5	61.7
22	61	34	33	14	37	44	72.5	88.2
26	65	37	35	14	41	45	82.5	97.0
30	74	43	37	16	48	50	95.6	145.5
34	80	50	42	16	52	55	105.6	187.4
40	88	55	45	16	58	60	125.6	229.3

**DIN1142 Malleable Wire Rope Clips
DIN1142 卡头**

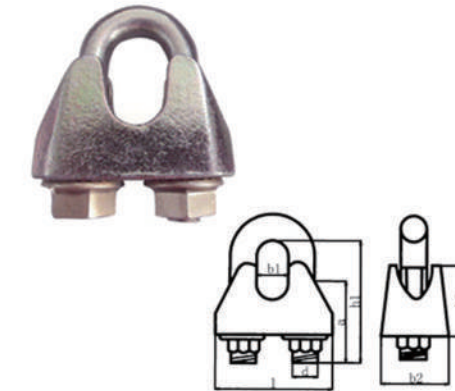

Size (mm)	Dimensions(mm)							Weight 100pcs(lbs)
	a	b1	b2	d	h1	h2	l	
5	13	7	13	5	25	13	25	5
6.5	17	8	16	6	32	14	30	9
8	20	10	20	8	41	18	39	18
10	24	12	20	8	46	21	40	20
13	30	15	28	12	64	29	55	61
16	35	18	32	14	76	35	64	95
19	36	22	32	14	83	40	68	108
22	40	24	34	16	96	44	74	150
26	50	26	38	20	111	51	84	258
30	55	34	41	20	127	59	95	309
34	60	38	45	22	141	67	105	470
40	65	44	49	24	159	77	117	591

Galv Malleable Wire Rope Clips Type A

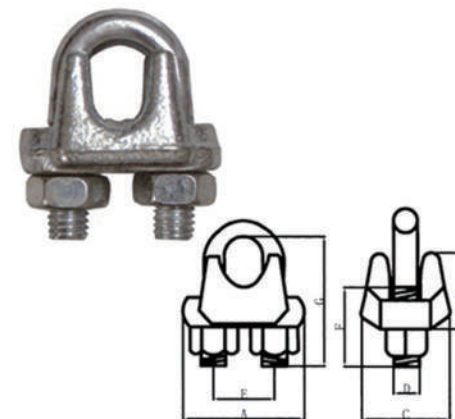

Size (mm)	Dimensions(mm)							Weight 100pcs(lbs)
	A	B	C	D	E	F	G	
6	23	14	17	5	12	14	24	5.5
8	28	17	21	6	15	16	30	9.9
10	38	21	28	8	19	20	37	19.84
12	45	27	34	10	24	25	47	39.68
15	52	32	40	12	29	30	56	61.73
20	62	38	46.5	14	36	36	70	103.62
22	69	43	51.5	16	40	39	77	136.68
25	76	50	56	18	43	44	85	187.4
28	85	57	62	20	48	48	95	264.55
32	93	61	67	22	55	51	108	346.12
40	111	73	81	24	64	62	120	575.4
45	123	86	88	27	72	70	137	800
50	135	95	95	30	80	88	154	1058.2

EYE HOOKS WITH LATCHES 320A/C

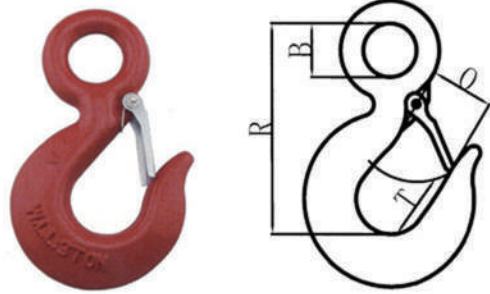

WLL(t)		Dimensions (in)					Weight(lbs)
320C	320A	B	R	O	T		
1/2	3/4	0.63	2.8	0.81	0.65	0.37	
3/4	1	0.75	3.22	0.88	0.81	0.57	
1	1 1/2	0.91	3.66	0.97	0.81	0.77	
1 1/2	2	1.12	4.09	1	0.84	1.28	
2	3	1.25	4.69	1.12	1.19	1.73	
3	4 1/2	1.56	5.78	1.34	1.38	3.66	
5	7	2	7.38	1.69	1.78	7.19	
7 1/2	11	2.44	9.06	2.06	2.12	13.17	
10	15	2.83	10.09	2.22	2.72	22.15	

CLEVIS SLIP HOOKS H-331/A-331

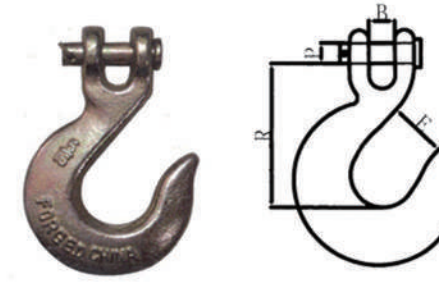

Size (in)	WLL(lbs)		Dimensions(in)				Weight (lbs)
	H-331	A-331	B	E	P	R	
1/4"	1950	2750	0.44	0.94	0.38	2.56	0.50
5 / 16"	2875	4300	0.50	1.66	0.44	2.87	0.75
3 / 8"	4000	5250	0.59	1.31	0.47	3.25	1.20
7/16"	5000	7000	0.66	1.56	0.56	3.70	2.06
1 / 2"	6500	9000	0.75	1.69	0.63	4.00	2.80
5/8"	9250	13500	0.91	2.00	0.75	4.94	4.75
3/4"	12500	19250	1.31	2.50	1.00	6.09	10.30

SWIVEL HOOKS 322A/C

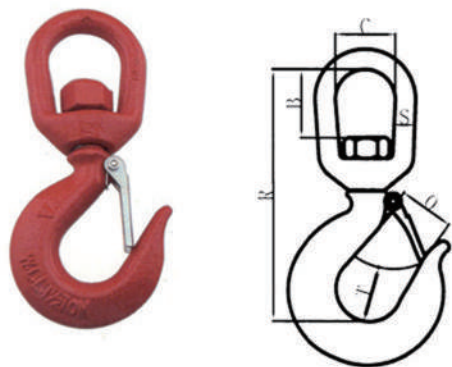

WLL(t)		Dimensions (in)						Weight (lbs)
322C	322A	B	C	O	R	S	T	
3/4	1	0.93	1.25	0.88	4.47	0.37	0.8	0.77
1	1 1/2	1.31	1.5	0.97	5.28	0.5	0.8	1.27
1 1/2	2	1.62	1.75	1	6	0.62	0.84	2.28
2	3	1.56	1.75	1.125	6.37	0.62	1.19	2.60
3	4 1/2	1.75	2	1.34	7.4	0.75	1.37	4.81
5	7	2.31	2.5	1.69	9.59	1	1.78	10.40
7 1/2	11	2.38	2.75	2.06	11.12	1.125	2.125	16.42
10	15	2.8	3.12	2.25	11.93	1.25	2.5	23.40

EYE GRAB HOOKS H-323/A-323



Size (in)	WLL(lbs)		Dimensions(in)			Weight (lbs)
	H-323	A-323	B	E	R	
1/4"	2600	3600	0.50	0.34	1.97	0.28
5/16"	3900	5400	0.56	0.44	2.25	0.45
3/8"	5400	7500	0.66	0.50	2.56	0.79
7/16"	7200	10000	0.75	0.56	2.94	1.19
1/2"	9200	12750	0.88	0.66	3.38	1.80
5/8"	12750	19000	1.06	0.78	4.11	3.30
3/4"	18500	27000	1.38	0.94	5.16	6.00

CLEVIS SLIP HOOKS WITH LATCHES

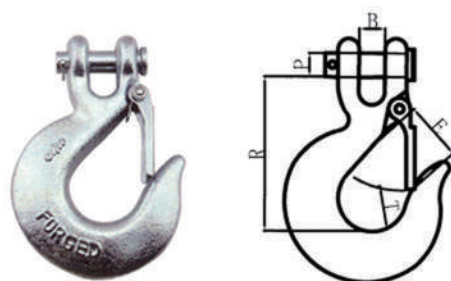

Size (in)	WLL(lbs)		Dimensions (in)					Weight (lbs)
	Carbon	Alloy	B	E	P	R	T	
1/4"	1950	2750	0.44	0.79	0.38	2.56	0.79	0.52
5/16"	2875	4300	0.50	0.93	0.44	2.87	0.79	0.77
3/8"	4000	5250	0.59	1.14	0.47	3.25	1.02	1.23
7/16"	5000	7000	0.66	1.18	0.56	3.70	1.06	2.10
1/2"	6500	9000	0.75	1.42	0.63	4.00	1.38	2.85
5/8"	9250	13500	0.91	1.65	0.75	4.94	1.69	5.18

CLEVIS GRAB HOOKS H-330/A-330

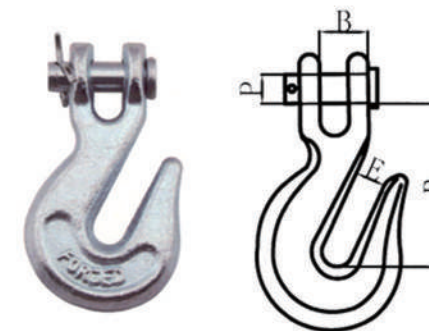

Size (in)	WLL(lbs)		Dimensions (in)				Weight (lbs)
	H-330	A-330	B	E	P	R	
1/4"	2600	3600	0.36	0.40	0.38	1.97	0.40
5/16"	3900	5400	0.40	0.44	0.44	2.26	0.79
3/8"	5400	7500	0.48	0.50	0.47	2.63	1.00
7/16"	7200	10000	0.66	0.56	0.56	2.75	1.50
1 / 2"	9200	12750	0.75	0.66	0.63	3.19	2.10
5/8"	12750	19000	0.91	0.78	0.75	4.09	4.20
3/4"	18500	27000	0.94	0.94	0.88	4.63	6.50

G80 CLEVIS Self-locking HOOK

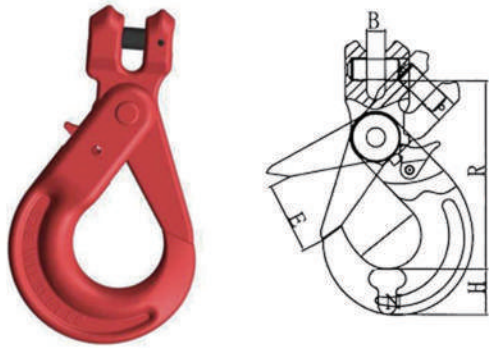

SIZE(mm)	WEIGHT (KG) 单重	WLL(T) 工作拉力	B. L (T)	E±2	B+0.5	H+1	N ±1.5	R
6-8	0.5	1.12	4.48	29	8.5	19.5	34	95.5
7/8-8	0.8	2	8	34	9.5	24	46	121
10-8	1.5	3.15	12.6	44	12	30	56	146
13-8	2.8	5.3	21.2	52	15	40	69	182
16-8	5.6	8	32	60	18	50.5	86	218
20-8	7.5	12.5	50	83	25	55	100	240
22-8	11.5	15	60	88	25.5	67	98	276.5
26-8	18.5	21.2	84.8	95.5	30	75	110	310.5
32-8	49.1	31.5	126	160	36	97	166	400.5

G80 CLEVIS SLING HOOK

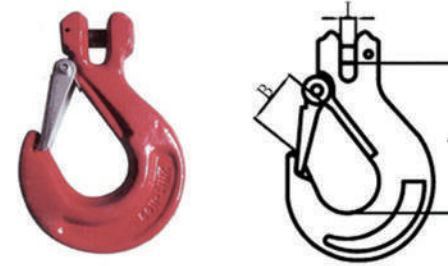

Size(mm)	Chain Size(mm)	WLL(t)	Test Load(t)	Die B	Dimensions(mm)		Weight (lbs)
					L	I	
6-8	5-6	1.1	2.2	22	73	6.7	0.66
7/8-8	7-8	2	4	25.5	86	8.7	1.21
10-8	10	3.15	6.3	30.8	105	10.2	2.32
13-8	13	5.3	10.6	41	128	15.3	4.19
16-8	16	8	16	50	155	19	7.83
20-8	19-20	12.5	25	60	184	21	13.04
22-8	22	15	30	71	222	36	16.1

G80 EYE Self-locking HOOK

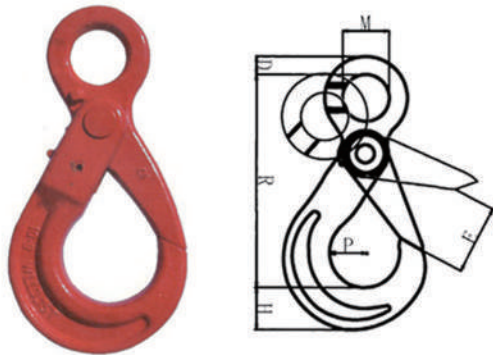

Size(mm)	Weight (lbs)	WLL(t)	B. L(t)	Dimensions(in)					
				M	R	D	P	H	E
6-8	1.1	1.12	4.48	22	110.5	10	34	19.5	28
7/8-8	1.8	2	8	25	136	12	46	24	34
10-8	3.2	3.15	12.6	32	171	15	56	30	44
13-8	6.3	5.3	21.2	40.5	208.5	19.5	69	40	52
16-8	12.4	8	32	56	257.5	22	86	50.5	60
18/20-8	16.8	12.5	50	64.5	275	27	100	55	81
22-8	28.7	15	60	70	320	30	98	67	82
26-8	39.7	21.2	84.8	80	363	34	110	75	110
32-8	98.2	31.5	126	105	472	45	166	97	168

G80 EYE SLING HOOK

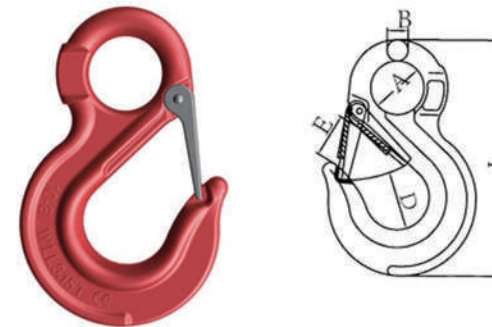

SIZE(mm)	WEIGHT (KG) 单重	WLL(T) 工作拉力	B. L(T)	B+1	E+1	D±1	A+1	L+2
6-8	0.3	1.12	4.48	9	24	21	20	108
7/8-8	0.4	2.0	8.0	11	30	26	25	133
10-8	0.9	3.15	12.6	15	34	39	38	167
13-8	1.7	5.3	21.2	19	39	54	43	213
16-8	3.2	8	32	23	46	64	50	255
20-8	5.8	12.5	50	24	40	80	62	305
22-8	8.5	15	60	32	71	80	62	348
26-8	13	21.2	84.8	35	81	82	64	394
32-8	17	31.5	126	37	102	112	88	480

G80 SWIVEL Self-locking HOOKS

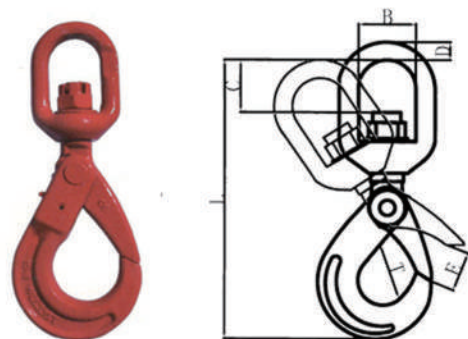

Size (mm)	Weight (lbs)	WLL(t)	B. L(t)	Dimensions in)					
				B	C	D	L	T	E
6-8	1.6	1.12	4.48	32.5	22	11.25	170	34	29
7/8-8	2.4	2	8	35.5	26	12.5	210	46	34
10-8	4.4	3.15	12.6	42	34	15	247	56	44
13-8	8.8	5.3	21.2	50	38.5	16	302	69	52
16-8	16.1	8	32	61	55	21.5	383	86	60
18/20-8	25.6	12.5	50	72	61	26	418	100	83
22-8	35.3	15	60	95	95	33	527	98	88
26-8	47.4	21.2	84.8	122	115	42	610	110	95.5
32-8	174.3	31.5	126	140	126	52	777	166	150

G80 EYE HOOK

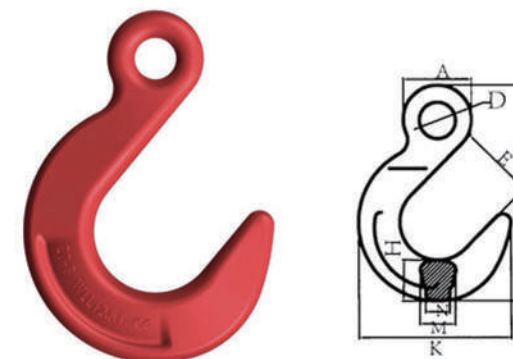

SIZE(mm)	WEIGHT (KG) 单重	WLL(T) 工作拉力	B. L(T)	E ±1.2	A ±1	D ±1	H ±1	M +1	N +0.5	K +2	L +2
7/8-8	1.09	2	8	63.5	39	18	31	25.4	1.8	1.20	1.63
10-8	2.04	3.15	12.6	76	50.8	22	38	32.6	2.3	1.46	2.00
13-8	3.22	5.3	21.2	89	63.5	27	44.5	38.1	2.7	1.71	2.38
16-8	5.53	8	32	102	76	32	52	46	3.2	1.98	2.78
20-8	8.75	12.5	50	114.5	89	38	65	55	3.9	2.32	3.25
22-8	11.93	15	60	127.5	102	45	69	57	4.0	2.56	3.61
26-8	16.8	21.2	84.8	140	126	67.5	77	66	4.5	2.83	4.02
32-8	26.6	31.5	126	153.5	151.5	81.5	97.5	80	5.8	3.27	4.61

MASTER LINK



ITEM NO.in	WEIGHT/KG	WLL / T	B. L / T	Amm	Bmm	Dmm
1/2	0.42	2.2	11	127	63.5	14
5/8	0.67	3.0	15	152	76	16
3/4	1.05	4.7	23.5	140	70	19
7/8	1.5	6.4	32	162	91	23
7/8	2.66	8	40	178	89	22
1	2.07	11	55	220	110	32
1-1/4	4.16	16	80	270	140	38
1-1/2	6.55	21.7	108.5	305	152	45
1-3/4	11.37	28.4	142	350	190	50
2	16.5	30	150	355	178	50
2-1/2	32	50	250	406	203	63

G80 EUROPEAN TYPE CONNECTING LINK



ITEM NO.mm	WEIGHT/KG	WLL/T	B.L/T	Amm	Lmm	Kmm	Hmm
6	0.68	1.12	4.48	15	58	42	7
7	0.145	1.5	6	19	71.8	54.8	8.5
7-8	0.146	2	8	18	79.5	62.5	8.5
8	0.16	2	8	18	79.5	60.5	8.5
10	0.3	3.15	12.6	25	93	68	10.8
13	0.7	5.3	21.2	29	117	87	15
16	1.1	8	32	34.5	148	108.4	19.8
18	1.84	10	40	38	154	112	21
18-20	1.8	12.5	50	41	169.5	121.5	24
22	3.2	15	60	48	193.5	141.5	26
26	4.5	21.2	84.8	57.5	229	158	30
32	9	31.5	126	67	281	205	37

MASTER LINK ASSEMBLY

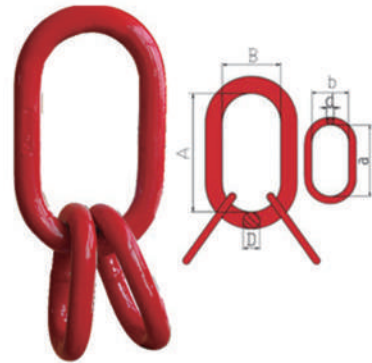

ITEMNO.	WEIGHT/KG	CHAIN(4:1)		CHAIN(5:1)		A	B	D	a	b	d	s
		WLL/T	B.L/T	WLL/T	B.L/T							
1/2	0.82	2.4	9.6	2	10	100	60	14	85	40	12	6
11/16	1.60	3.2	12.8	2.5	12.5	160	90	18	100	60	14	7.6
3/4	1.95	5	20	4	20	160	90	20	100	60	14	7.6
7/8	3.16	8	32	6.4	32	180	100	22	150	70	18	8.4
1-1/8	6.75	12	48	9.6	48	270	140	28	160	90	22	13.5
1-1/4	9.31	17.4	69.6	13.9	69.5	270	140	32	180	100	25	16.5
1-1/2	18.4	21	84	21	105	300	160	40	270	140	31	-
1-3/4	26.4	30	120	30	150	340	180	45	285	155	36	-
2	42.91	40	160	40	200	350	190	51	340	180	45	-

DIN 580 EYE BOLT

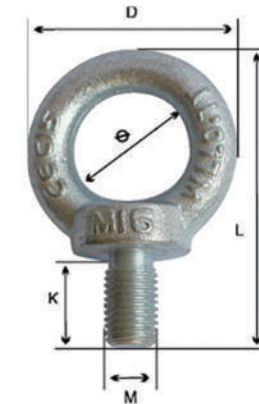

ITEM NO.	WEIGHT/KG	WLL/T(4:1)		Dmm	Kmm	phi mm	Lmm
		WLL 0°	WLL 90°				
M6	0.05	0.4	0.15	28	13	16	42
M8	0.06	1	0.4	36	15	20	51
M10	0.11	1	0.4	45	18	25	63
M12	0.18	2	0.75	54	22	30	75
M16	0.28	4	1.5	63	28	35	88
M20	0.45	6	2.3	72	30	40	101
M24	0.87	8	3.2	90	38	50	128
M30	1.66	12	4.5	108	45	60	154
M36	2.85	16	7	126	55	70	183
M42	4.03	24	9	144	65	80	212
M48	6.38	32	12	166	70	90	238

FORGED RING

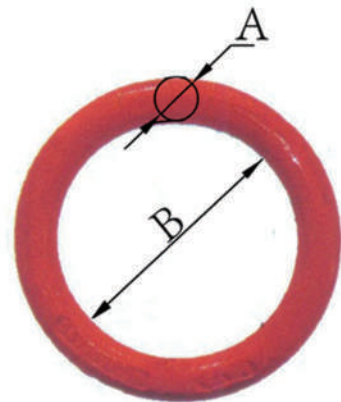

SIZE	WEIGHT (KG)	WLL	A	B
3/4*4	1.14	1.8T	19	102
7/8*4	1.6	3.5T	22	102
7/8*4	1.6	3.5T	22	140
1*4	1.6	4.5T	25	102
1-1/8*6	2.8	6.5T	28	152
1-1/4*6	3.6	9T	32	152
1-1/4*10	6	9T	32	254
1-1/2*6	5.4	10T	35	152
1-1/2*8	6.8	10T	38	203
1-1/2*10	8.4	10T	38	254

DIN 580 EYE NUT

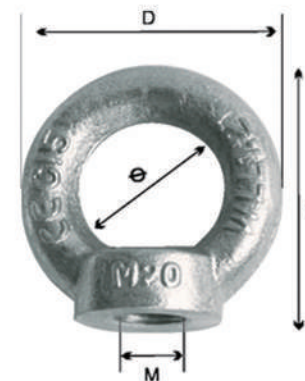

ITEM NO.	WEIGHT/KG	WLL/T(4:1)		Dmm	phi mm	Lmm
		WLL 0°	WLL 90°			
M6	0.049	0.4	0.15	36	20	36
M8	0.05	1	0.4	36	20	36
M10	0.09	1	0.4	45	25	45
M12	0.16	2	0.75	54	30	53
M16	0.24	4	1.5	63	35	62
M20	0.36	6	2.3	72	40	71
M24	0.72	8	3.2	90	50	90
M30	1.32	12	4.5	108	60	109
M36	2.08	16	7	126	70	128
M42	3.11	24	9	144	80	147
M48	5.02	32	12	166	90	168

EYE SCREW JIS 1168

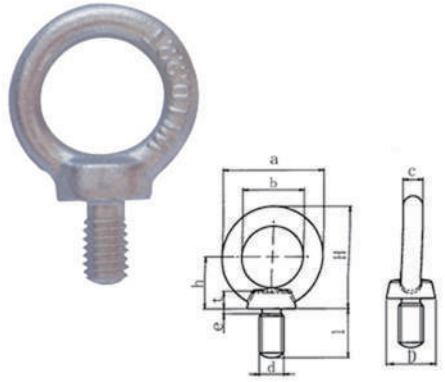

SIZE		Dimensions										W.L.L		WEIGHT	
M	W	a	b	c	D	t	h	H	I	E	M	W	KN	KN	EACH
		MM	MM	MM	MM	MM	MM	MM	MM	MM	MM	MM	MM	MM	KGS
6	1/4	26	16	5.8	13.5	6	14	27	14	2	0.588			0.016	
8	5/16	32.6	20	6.3	16	5	17	33.3	15	3	0.785			0.03	
10	3/8	41	25	8	20	7	21	41.5	18	4	1.47	1.37		0.06	
12	1/2	50	30	10	25	9	26	51	22	5	2.16	2.16		0.12	
16	5/8	60	35	12.5	30	11	30	60	27	5	4.41	3.92		0.22	
20	3/4	72	40	16	35	13	35	71	30	6	6.18	5.88		0.39	
24	1	90	50	20	45	18	45	90	38	8	9.32	9.32		0.8	
30	1-1/4	110	60	25	60	22	55	110	45	8	14.7	14.7		1.56	
36	1-1/2	133	70	31.5	70	26	65	131.5	55	10	22.6	22.6		2.9	
42	1-3/4	151	80	35.5	80	30	75	150.5	65	12	33.3	33		4.4	
48	2	170	90	40	90	35	85	170	70	12	44.1	44.1		6.1	
64	2-1/2	210	110	50	110	42	105	210	90	14	88.3	88.3		11.5	

CHAIN SWIVELS G-401

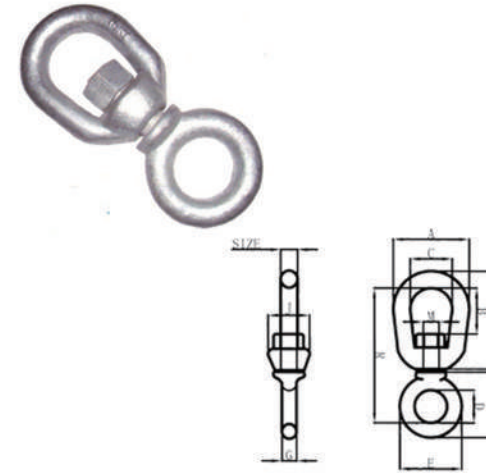

Size (in)	Dimensions(in.)											WLL (lbs)	Weight (lbs)
	A	B	C	D	E	G	J	M	R	U	V		
1/4	1.25	0.69	0.75	0.62	1.12	0.25	0.69	0.31	2.25	1.69	1.25	850	0.13
5/16	1.63	0.81	1.00	0.75	1.38	0.31	0.81	0.38	2.72	2.06	1.47	1,250	0.25
3/8	2.00	0.94	1.25	1.00	1.75	0.38	1.00	0.50	3.44	2.50	1.88	2250	0.54
1/2	2.50	1.31	1.50	1.25	2.25	0.50	1.31	0.63	4.25	3.19	2.44	3,600	1.12
5/8	3.00	1.56	1.75	1.50	2.75	0.62	1.50	0.75	5.13	3.88	2.94	5,200	2.09
3/4	3.50	1.75	2.00	1.75	3.25	0.75	1.88	0.88	5.78	4.94	3.46	7,200	3.09

EYE SCREW JIS 1168

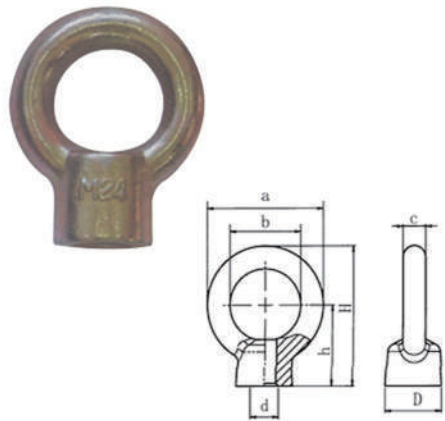

SIZE		Dimensions										W.L.L		WEIGHT	
M	W	a	b	c	D	t	h	H	I	E	M	W	KN	KN	EACH
		MM	MM	MM	MM	MM	MM	MM	MM	MM	MM	MM	MM	MM	KGS
6	1/4	25	14	6.3	13	6	20	32.5	0.588					0.016	
8	5/16	32.6	20	6.3	16	8	23	39.3	0.785					0.026	
10	3/8	41	25	8	20	10	28	48.5	1.47	1.37				0.064	
12	1/2	50	30	10	25	12	36	61	2.16	2.16				0.125	
16	5/8	60	35	12.5	30	16	42	72	4.41	3.92				0.223	
20	3/4	72	40	16	35	20	50	86	6.18	5.88				0.39	
24	1	90	50	20	45	24	66	111	9.32	9.32				0.85	
30	1-1/4	110	60	25	60	30	80	135	14.7	14.7				1.75	
36	1-1/2	133	70	31.5	70	36	95	161.5	22.6	22.6				3	
42	1-3/4	151	80	35.5	80	42	109	184.5	33.3	33.3				4.65	
48	2	170	90	40	90	48	123	208	44.1	44.1				6.6	
64	2-1/2	210	110	50	110	64	151	256	88.3	88.3				13.8	

REGULAR SWIVELS G-402

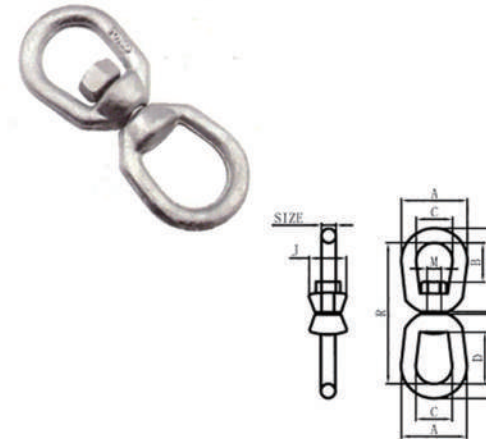

Size (in)	WLL(lbs)	Dimensions(in)								Weight (lbs)
		A	B	C	D	J	M	R	S	
1/4	850	1.25	0.69	0.75	1.06	0.69	0.31	2.94	1.69	0.21
5/16	1,250	1.63	0.81	1	1.25	0.81	0.38	3.56	2.06	0.39
3/8	2,250	2	0.94	1.25	1.5	1	0.5	4.31	2.5	0.71
1/2	3,600	2.5	1.31	1.5	2	1.31	0.63	5.44	3.19	1.32
5/8	5,200	3	1.56	1.75	2.38	1.5	0.75	6.56	3.88	2.49
3/4	7,200	3.5	1.75	2	2.63	1.88	0.88	7.19	4.31	4.02
7/8	10,000	4	2.06	2.25	3.06	2.13	1	8.38	5	6.25
1	12,500	4.5	2.31	2.5	3.5	2.38	1.13	9.63	5.75	8.95
1 1/4	18,000	5.63	2.69	3.13	3.69	3	1.5	11.44	6.75	16.37
1 1/2	45,200	7.09	3.88	4.09	3.88	3.75	2.25	16.69	9.91	45.79

SWIVELS LINK



ITEM NO.	WEIGHT/KG	WLL/T	B./T	Amm	Dmm	Hmm	Lmm
2T	0.6	2	8	12.5	35.5	28.5	164
3.15T	1.5	3.15	12.6	15	42	34.5	194
5.3T	1.75	5.3	21.2	18	50	43.5	216
8T	4.52	8	32	21.5	61	56	289

JAW END SWIVELS G-403

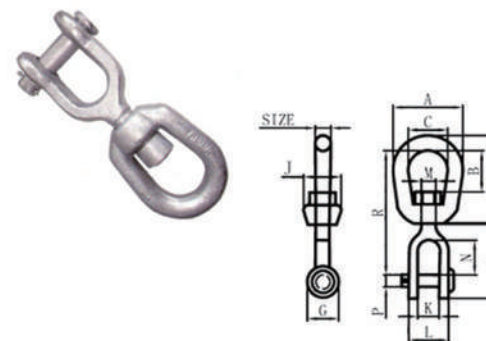

Size (in)	Dimensions(in)														W.L.L (lbs)	Weight (lbs)
	A	B	C	G	J	K	L	M	N	P	R	U	V			
1/4	1.25	0.69	0.75	0.69	0.69	0.47	1.03	0.31	0.88	0.25	2.63	1.69	1.69	850	0.21	
5/16	1.63	0.81	1	0.81	0.81	0.5	1.13	0.38	0.88	0.31	2.94	2.06	1.81	1,250	0.34	
3/8	2	0.94	1.25	1	1	0.63	1.41	0.5	1.06	0.38	3.63	2.5	2.25	2,250	0.66	
1/2	2.5	1.31	1.5	1.31	1.31	0.75	1.75	0.63	1.31	0.5	4.5	3.19	2.88	3,600	1.34	
5/8	3	1.56	1.75	1.63	1.5	0.94	2.06	0.75	1.5	0.63	5.31	3.88	3.44	5,200	2.48	
3/4	3.5	1.75	2	1.88	1.88	1.13	2.53	0.88	1.75	0.75	6.06	4.31	4	7,200	3.88	
7/8	4	2.06	2.25	2.13	2.13	1.19	2.75	1.13	2.81	1.13	8.56	5.75	5.94	10,000	5.87	
1	4.5	2.31	2.5	2.63	2.38	1.75	3.72	1.13	2.81	1.13	11.44	6.75	7.06	12,500	9.84	
1 1/4	5.63	2.69	3.13	3.13	3	2.06	4.31	1.63	2.81	1.38	16.69	9.91	10.84	18,000	15.75	
1 1/2	7	3.88	4	5.63	4	2.88	6	2.25	4.44	2.25	22.5	14.25	10	45,200	54.75	

Stainless Steel Dee Shackle

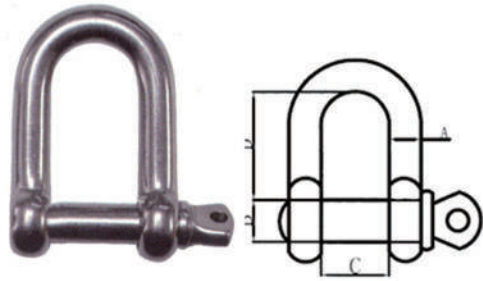

Size (mm)	Dimensions(mm)				WLL (kg)
	A	B	C	D	
4	4	4	8	16	80
5	5	5	10	20	100
6	6	6	13	24	200
8	8	8	16	32	320
10	10	10	20	40	520
12	12	12	24	48	800
14	14	14	28	56	1100
16	16	16	32	64	1500
18	18	18	36	72	2100
20	20	20	40	76	3000
22	22	22	44	88	3500
25	25	25	50	100	5000
28	28	28	56	112	7000
32	32	32	64	128	8000

Stainless Steel Bow Shackle

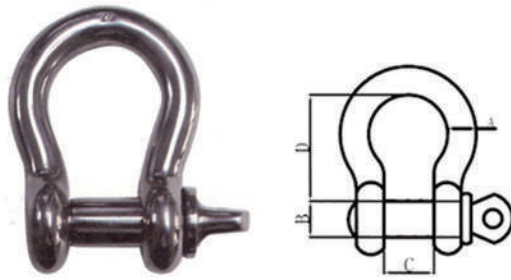

Size (mm)	Dimensions(mm)				WLL (kg)
	A	B	C	D	
4	4	4	8	16	80
5	5	5	10	19	100
6	6	6	12	24	200
8	8	8	16	32	320
10	10	10	20	40	520
12	12	12	24	48	800
14	14	16	28	56	1100
16	16	20	32	64	1500
18	18	22	36	72	2100
20	20	25	40	76	3000
22	22	28	44	88	3500
25	25	32	50	100	5000

Stainless Steel Closed Body Turnbuckle

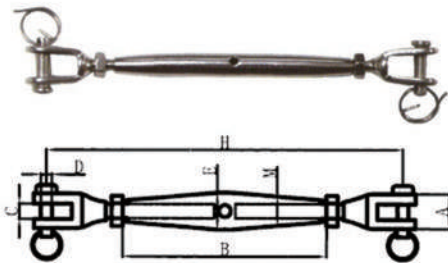

Size (mm)	Dimensions (mm)						
	M	A	B	C	D	E	H
5	5	12.5	80	7.5	4.8	8.5	128
6	6	15	92	9	5.8	10	145
8	8	17	112	11	7.8	13.5	174
10	10	20	120	12	9.8	17	204
12	12	24	150	15	11.8	21	256
14	14	28	170	18	13.8	23	290
16	16	32.6	190	21	15.8	27	327
20	20	37	210	24	19.8	33	380
22	22				21.8		14
24	24				23.8		
36	36	69	300	45	35		584

Stainless Steel Turnbuckle

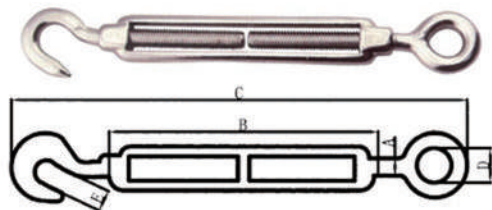

Size (mm)	Dimensions(mm)				WLL(t)	Weight (lbs)
	A	B	C	D		
5	70	120	8		0.04	0.11
6	90	160	10		0.1	0.19
8	120	200	14		0.2	0.38
10	150	240	16		0.3	0.68
12	200	300	18		0.5	1.37
16	250	390	26		0.8	3.05
20	300	440	30		1.2	5.74

Stainless Steel Eye Bolt DIN-580

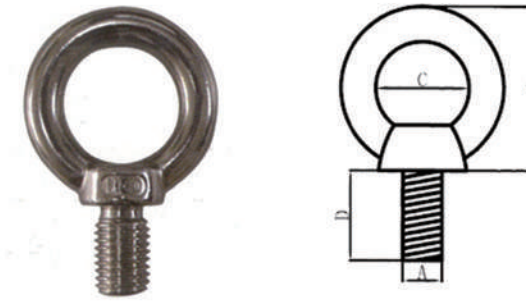

Size (mm)	Dimensions(mm)				WLL (t)
	A	B	C	D	
6	6	28	16	13	0.07
8	8	36	20	14	0.14
10	10	45	25	17	0.23
12	12	53	30	21	0.34
16	16	62	35	27	0.7
20	20	71	40	30	1.2
24	24	90	50	36	1.8
30	30	109	60	45	3.6

Stainless Steel Eye Nut DIN-582

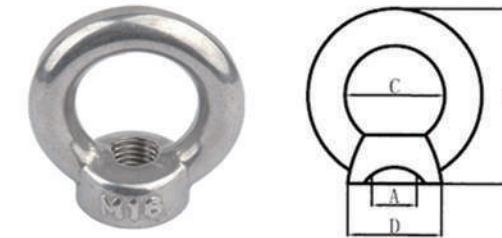

Size(mm)	Dimensions(mm)				WLL (t)
	A	B	C	D	
6	6	28	16	20	0.07
8	8	36	20	20	0.14
10	10	45	25	25	0.23
12	12	53	30	30	0.34
16	16	62	35	35	0.7
20	20	71	40	40	1.2
24	24	90	50	50	1.8
30	30	109	60	60	3.6

Stainless Steel Eye Swivel

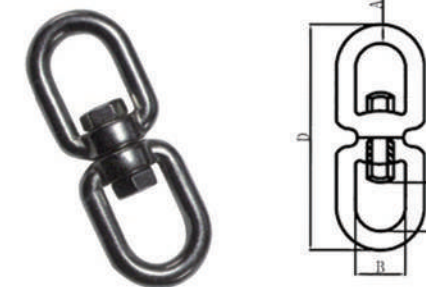

Size (mm)	Dimensions(mm)				WLL(kg)	BL (kg)
	A	B	C	D		
4	4	11.5	13	50	113	450
5	5	13	14	60	163	650
6	6	14.5	15.5	66.5	300	1200
8	8	19.5	21.5	90	475	1900
10	10	23.5	26	112	875	3500
13	13	33	33.5	148	1250	5000
16	16	38	42.5	186	2125	8500
20	19	40.5	51	223	2500	10000
22	22	48.5	61	258	2875	11500
25	25	65	73	290	3250	13000

Stainless Steel Wire Rope Clip

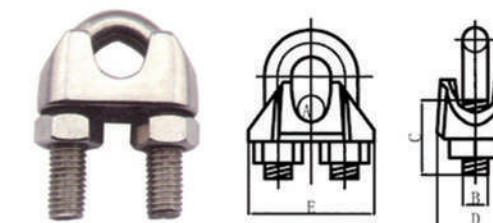

Size (mm)	Dimensions(mm)					Weight (lbs)
	A	B	C	D	E	
3	3	4	12	10	21	0.03
5	5	5	13	11	23	0.033
6	6	5	15	12	26	0.046
8	8	6	19	14	30	0.09
10	10	8	22	18	34	0.15
11	11	8	22	19	36	0.16
13	13	10	30	23	42	0.29
14	14	10	30	23	44	0.3
16	16	12	33	26	50	0.46
19	19	12	38	29	54	0.62
22	22	14	44	33	61	0.88
25	25	14	45	35	65	0.97

EUROPEAN TYPE THIMBLE

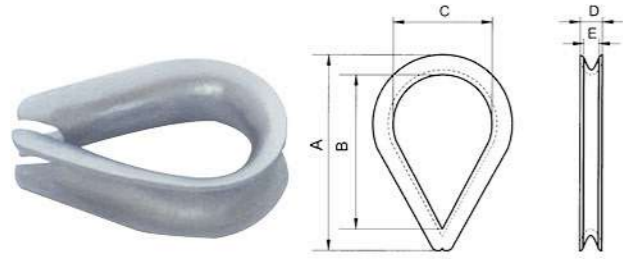

SIZE MM	A MM	B MM	C MM	D MM	E MM
4	25	20	11	7	4
5	31	24	15	8	5
6	37	29	18	10	6
7	44	34	22	11	7
8	51	38	24	12	8
10	64	46	30	14	10
12	76	57	38	18	12
14	82	60	40	20	14
16	89	64	42	22	16
18	102	69	45	26	18
20	115	79	51	28	20
22	127	89	54	30	22
24	140	102	64	34	26
26	152	105	64	34	28
28	165	115	73	38	30
30	178	121	79	44	32
32	203	133	93	46	34

THIMBLE DIN6899A

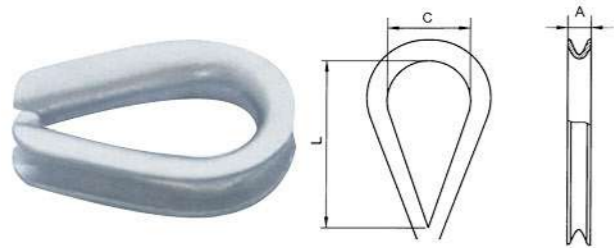

Seil-φ MM	A MM	L MM	C MM	Seil-φ MM	A MM	L MM	C MM
10.0	11.0	47.5	22	2.5	3.0	21.5	10
11.0	12.0	51.5	24	3.0	3.5	23.5	11
12.0	13.0	56.5	26	3.5	4.0	26.5	12
13.0	14.0	61.0	28	4.0	5.0	28.5	13
15.0	16.0	69.5	32	5.0	6.0	30.0	14
16.0	18.0	78.0	35	6.0	7.0	33.0	15
18.0	20.0	86.5	40	7.0	8.0	35.0	16
20.0	22.0	95.0	44	8.0	9.0	39.0	18
24/26	26.0	105.0	48	9.0	10.0	43.0	20

THIMBLE DIN6899 B

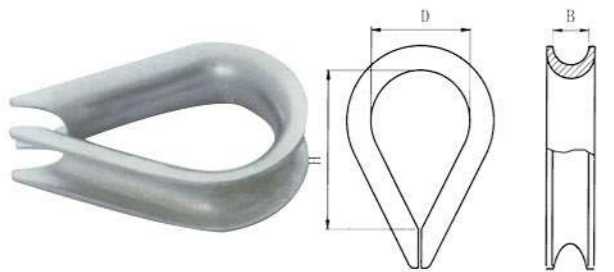

SIZE MM	B MM	H MM	D MM	SIZE MM	B MM	H MM	D MM
2.5-3	3.0	19.0	12	16-18	18	64	40
3.5-4	4.0	21.0	13	18-20	20	72	45
4.0-5	5.0	23.0	14	20-22	22	80	50
5.0-6	6.0	25.0	16	22-24	24	90	56
6.0-7	7.0	28.0	18	24-26	26	99	62
7.0-8	8.0	32.0	20	26-28	28	112	70
9.0-10	10.0	38.0	24	28-30	30	120	75
11.0-12	12.0	45.0	28	30-32	32	128	80
12.0-13	13.0	48.0	30	32-34	34	152	95
13.0-14	14.0	51.0	32	34-36	36	160	100
15.0-16	15.0	58.0	36	36-38	38	176	110

U.S. TYPE REGULAR DUTY THIMBLE G-411



Seil-φ MM	A MM	L MM	C MM
1/8"	4	33.27	17.5
3/16"	5	33.27	17.5
1/4"	7	33.27	17.5
5/16"	8.6	38	20.57
3/8"	10.4	41	23.88
1/2"	13.5	47.75	28.7
5/8"	16.8	57.15	35.05
3/4"	19.8	63.5	41.4
7/8"	23.88	88.9	47.75
1"	26.92	107.95	63.5
1 1/8"-1 1/4"	33.27	114.3	69.85

U.S. TYPE HEAVY DUTY THIMBLE G-414

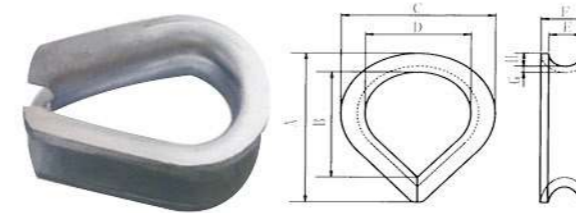

Rope DIA		DIMENSIONS(in)							
in	lbs.	A	B	c	D	E	F	G	H
1/4	6.75	2.19	1.63	1.50	0.88	0.41	0.28	0.06	0.23
5/16	11.25	2.50	1.88	1.81	1.06	0.50	0.34	0.08	0.28
3/8	25.00	2.88	2.13	2.13	1.13	0.63	0.41	0.11	0.34
7/16	30.00	3.25	2.38	2.38	1.25	0.72	0.47	0.13	0.38
1/2	51.00	3.63	2.75	2.75	1.50	0.81	0.53	0.14	0.41
9/16	51.00	3.63	2.75	2.69	1.50	0.88	0.59	0.14	0.41
5/8	75.00	4.25	3.25	3.13	1.75	0.97	0.66	0.16	0.50
3/4	147.00	5.00	3.75	3.81	2.00	1.22	0.78	0.22	0.66
7/8	175.00	5.50	4.25	4.25	2.25	1.38	0.94	0.22	0.75
1	275.00	6.13	4.50	4.94	2.50	1.56	1.06	0.25	0.88
1 1/8"- 1/4"	400.00	7.00	5.13	5.88	2.88	1.81	1.31	0.25	1.13
1 1/4"-13/8"	817.00	9.06	6.50	6.81	3.50	2.19	1.44	0.38	1.13
13/8"-1 1/2"	7500.00	9.00	6.25	7.13	3.50	2.56	1.56	0.50	1.13
15/8"	1700.00	11.25	8.00	8.13	4.00	2.72	1.72	0.50	1.38
13/4"	1775.00	12.19	9.00	8.50	4.50	2.84	1.84	0.50	1.31
17/8"-2"	2500.00	15.13	12.00	10.38	6.00	3.09	2.09	0.50	1.50
2 1/4"	3950.00	17.13	14.00	11.88	7.00	3.63	2.38	0.63	1.63

COMMERCIAL TYPE THIMBLE

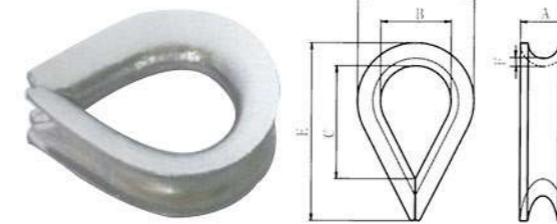

SIZE mm	DIMENSIONS(mm)						WT/100PCS (KG)
	A	B	C	D	E	F	
6MM	11	19	30	29	38	2.5	1.7
8MM	13	21	35	30	45	2.5	3.4
10MM	16	25	38	37	51	3	4.4
12MM	18	32	49	45	64	3	7.3
16MM	22	45	75	59	90	3.2	15.5
20MM	25	49	81	67	102	4.8	20
22MM	32	55	89	78	114	4.8	28
24MM	33	59	99	82	127	5.5	40

BS464 THIMBLE

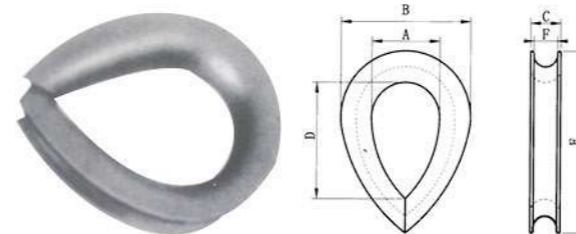

Nominal Dia of Rope	Approx Circle	A		B		C		D		E		F		
		in	mm	in	mm	in	mm	in	B	E	B	B	E	
5/16	8	1	7/8	22.2	11/2	38	15/16	33.4	21/8	52	5/32	4	13/16	30.1
3/8	9	1 1/4	1	25.4	17/8	47.6	11/2	38	21/2	64	1/4	6.3	13/8	35
7/16	11	1 1/2	1 1/8	28.6	21/8	52	11/2	41.3	27/8	73	5/16	7.9	11/2	38
1/2	13	1 5/8	1 1/4	31.7	25/16	58.8	13/4	44.5	31/8	79.4	5/16	7.9	11/6	42.9
9/16	14	1 3/4	1 1/4	31.7	25/16	58.8	13/4	44.5	31/8	79.4	5/16	7.9	11/6	42.9
5/8	16	2	1 5/8	41.3	25/16	74.5	25/16	58.8	37/8	95.8	11/32	8.7	21/4	56
11/16	17	2 1/4	1 3/4	44.5	31/8	79.4	25/8	66.6	41/4	108	3/8	9.5	23/8	60.4
3/4	19	2 3/8	2	50.8	35/8	92	27/8	73	47/8	124	7/16	11.1	23/4	69.8
13/16	21	2 1/2	2	50.8	35/8	92	27/8	73	47/8	121	7/16	11.1	23/4	69.8
7/8	22	2 3/4	2 1/4	56	4	102	31/4	82.5	41/4	131	1/2	12.7	3	76.2
15/16	24	3	2 1/2	64	51/16	110	35/8	92	53/4	146	1/2	12.7	35/16	84
1	25	3 1/4	2 3/4	69.8	41/16	119	41/4	108	63/8	162	9/16	14.3	39/16	90.5
1 1/8	29	3 1/2	3	76.2	51/4	133	43/8	112	7	178	5/8	15.9	4	102
1 1/4	32	4	3 3/4	95	6	152	51/4	133	73/4	197	5/8	15.9	43/4	121

TUBE THIMBLE



rope MM	A MM	B MM	C MM	D MM
10	12	90	23	4
12	15	105	27	5
14	17	115	27	4
16	19	120	32	5
18	22	140	35	5
22	25	180	45	6
25	30	195	47	7
32	35	215	60	7
38	45	260	70	7